

TYPICAL CROSS SECTION DETAILS
1.5m CONCRETE PATHWAY

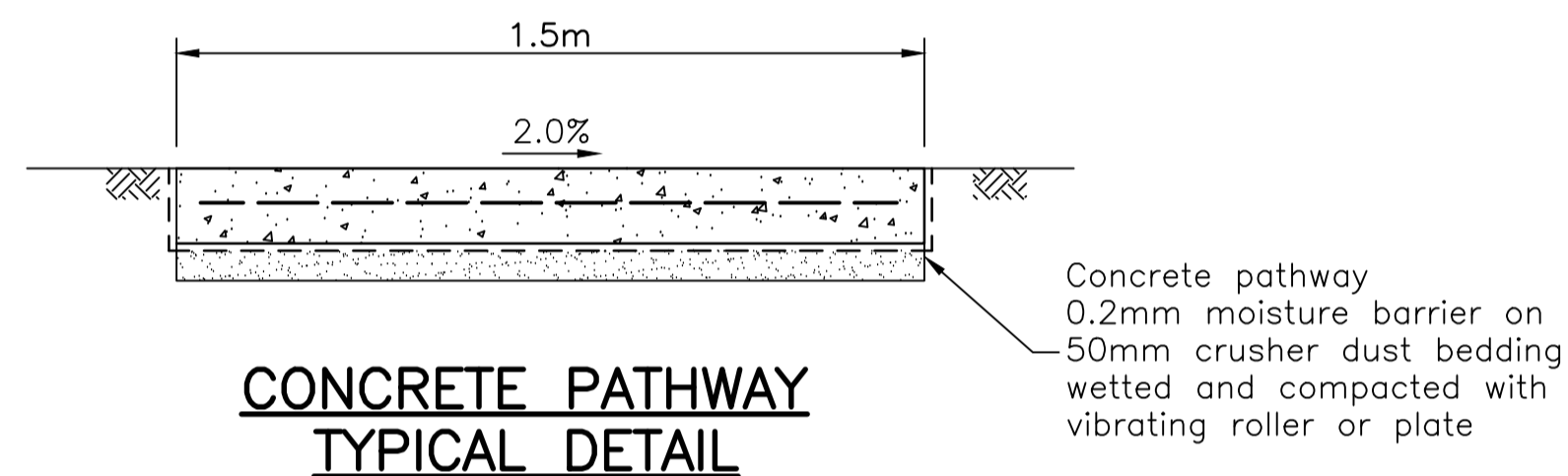

CONCRETE PATHWAY TYPICAL DETAIL

ASSOCIATED STANDARD DRAWINGS

- Driveway Construction
Refer:
SD-030 Driveway Access Urban and
SD-031 Driveway Access Industrial
SD-032 Driveway Crossovers Urban

AUS SPEC CONSTRUCTION DOCUMENTS

- CQC Quality Control Requirements
- C101 General
- C201 Control Of Traffic
- C211 Control Of Erosion & Sediment
- C213 Earthworks
- C224 Open Drains Including Kerb & Channel
- C271 Minor Concrete Works

CONCRETE THICKNESS AND REINFORCEMENT OPTIONS

REINFORCING TYPE	PATHWAY LOCATION/DETAILS		
	Footpath	Urban Driveway	Industrial/Commercial Driveway
Mesh	100mm N32 SL72	125mm N32 SL72	175mm N32 SL92
Cover	Centrally	Centrally	50mm top

NOTES:
GENERAL

1. This drawing shall be read in conjunction with the design drawings, specifications and written instructions as may be issued during the course of construction. All discrepancies shall be reported immediately for decision before proceeding with the project.
2. Where proposed path does not abut existing kerb, path surface to finish as close as possible to existing surface. Maximum crossfall on path is 2.5%, maximum longitudinal grade is 1 in 14.
3. It is desirable to provide minimum clearances of 0.5m from property boundary and 1.0m from back of kerb. It is preferred to align the pathway outside the underground services locations situated in the road reserve, working from back of kerb as the first option.
4. Kerb ramps to be constructed in accordance with Townsville City Council standard drawing SD-025.
5. Where pathway replaces a residential driveway, upgrade concrete depth to 150mm and place SL62 mesh with 40mm top cover. Where driveways are too steep the pathway may need to be diverted towards the property boundary to achieve 2.0% crossfall.
6. Proposed footpath location is based on site investigations. Confirm all measurements on site prior to excavation. Do not scale these drawings, use figured dimensions.
7. Refer IPWEAQ Std Dwgs D-0040 & D-0041 for Sediment Control Devices.

CONCRETE

1. Concrete shall be Grade N32 minimum.
2. Concrete cover to reinforcement shall be 40mm unless otherwise noted.
3. All concrete must be cured in accordance with the following:
 - AS3600
 - Aliphatic alcohol must be used. The aliphatic alcohol should be applied after screeding & bull floating operations.
 - No water should be added to concrete.
 - An impermeable membrane should be applied. All joints in membrane are to be taped and the edges secured to prevent the ingress of air.
 - Minimum curing period shall be not less than 7 days for strength grade N25 and not less than 4 days for high early strength concrete.
4. Exposed edges of formed concrete elements shall have a 20mm chamfer unless otherwise noted.
5. All concrete shall be mechanically vibrated. Hand held vibrators must be held upright. Concrete must not be spread using vibrator.
6. Stiff broom finish to surface.

JOINTS

1. Provide contraction joints (CJ) at a maximum spacing approximately 1.5 times the width of the concrete path. Cut every second bar of mesh under joint. Saw cut joint shall be a wet cut within 24 hours of concrete pour.
2. Provide key joint (KJ) at 6.0m maximum spacing.
3. Provide expansion joint (EJ) at 12.0m maximum spacing. Joints to be filled with approved filler and sealant.
4. Construction joint to be provided adjacent to all concrete property crossings and any significant change in width and direction.

VEGETATION

1. Grassed area disturbed by construction shall be trimmed and revegetated on completion of the pathway. Where the existing footpath is well grassed and maintained, provide a 0.5m wide strip of turf to both sides of pathway. Turfing to match existing grass species where possible. Where existing footpath is bare or not maintained, provide a 0.5m wide strip of good quality topsoil. Disturbance to established vegetation should be minimised during construction.
2. Contractor to liaise with the resident and Parks Services prior to the removal of any trees. Parks Services to supply and replant replacement trees of an appropriate species where indicated, including establishment activities for up to 4 weeks.
3. Grind tree stumps to a minimum of 500mm below finished ground level, backfill with crusher dust and 50mm topsoil at surface.
4. The construction site shall conform to the requirements of Environment Management.

SERVICES

1. Existing irrigation pipes and sprinklers disturbed by construction is to be reinstated with sprinkler heads placed 0.5m from the face of kerb.
2. Fire Hydrants and Sluice valves disturbed by the construction of the pathway are to be made flush with the pathway and recapped appropriately.
3. Locate all property drain outlets in kerb and ensure they remain in service when construction is complete.
4. Electricity, Telecommunications and Gas service covers that are disturbed by the construction of the pathway are to be made flush with the pathway and recapped appropriately. Refer to the relevant Authority for the work to be carried out.

EXISTING PERMANENT SURVEY MARKS AND IRON PINS

1. The Contractor shall arrange for the TCC Surveyor to locate and expose the existing PSM's and Iron Pins.
2. Where the PSM and Iron Pin location clashes with the pathway alignment, a cast iron cover box shall be installed and finished flush with the final path level as directed by the TCC Surveyor.
3. The alignment of the path may be varied to preserve the PSM's and Iron Pins.

FOR REINFORCED CONCRETE (FIBRE) ALTERNATIVE
REFER DRAWING SD-075

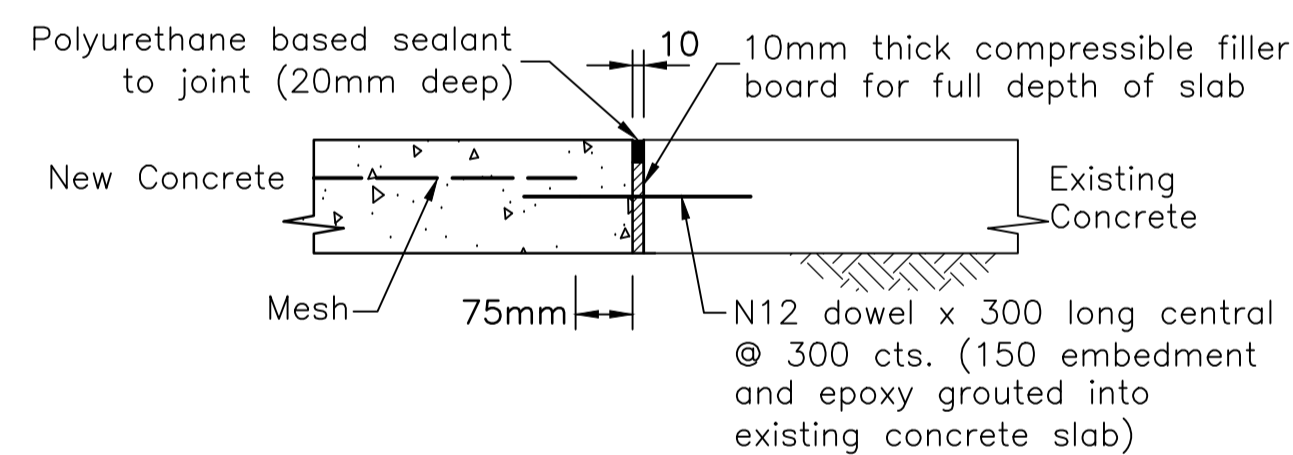

KEY CONSTRUCTION JOINT - KCJ
Key Construction Joints to be provided between all abutting new and existing concrete works

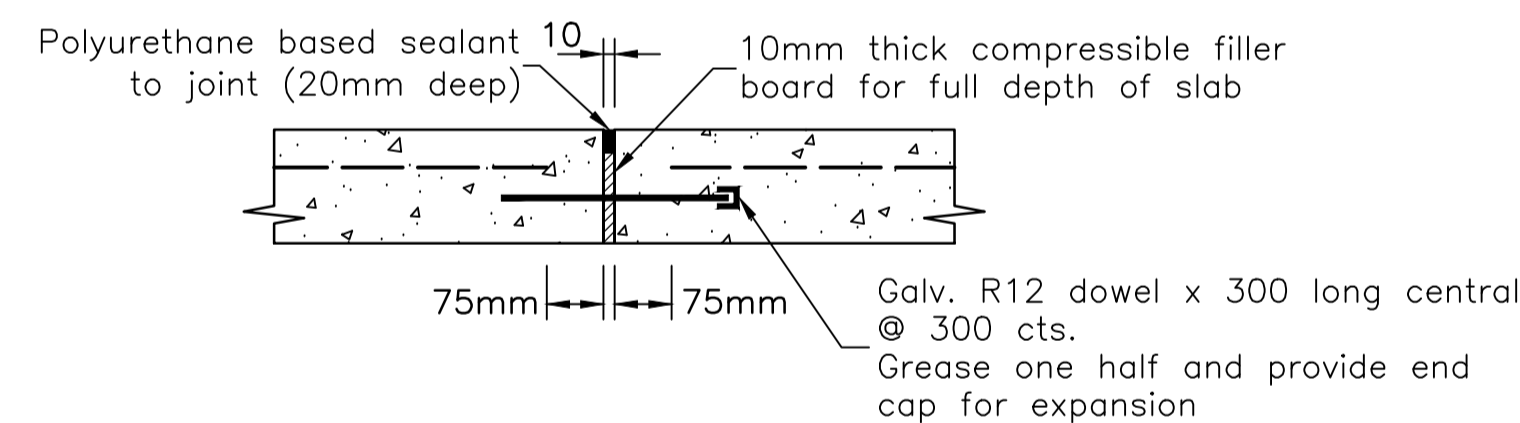

EXPANSION JOINT - EJ
(Max. 12.0m spacing)

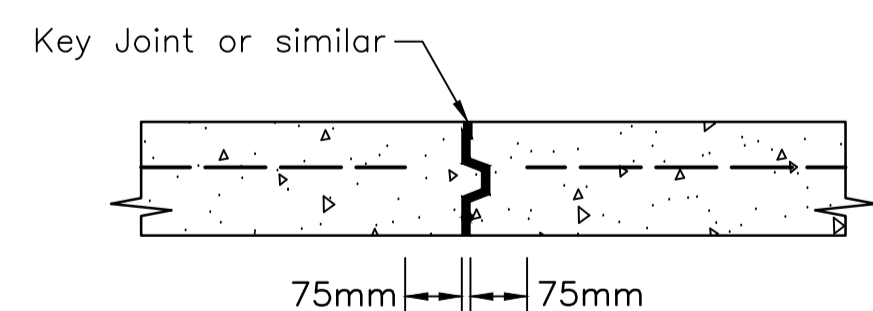

KEY JOINT - KJ
(Max. 6.0m spacing)

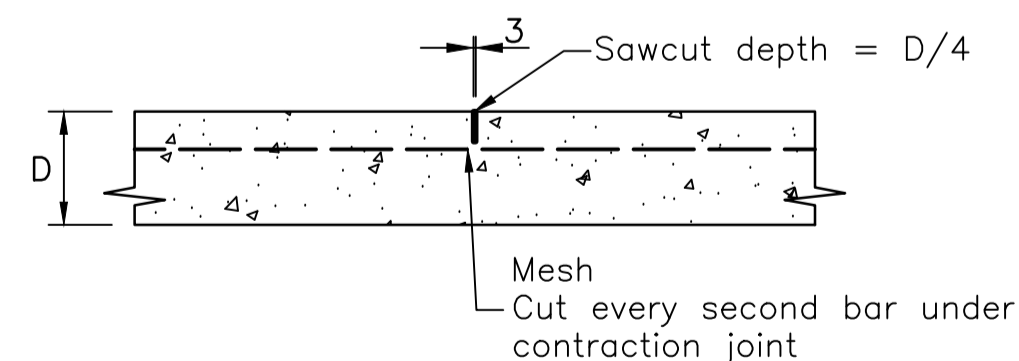

CONTRACTION JOINT - CJ
(Max. 3.0m spacing)

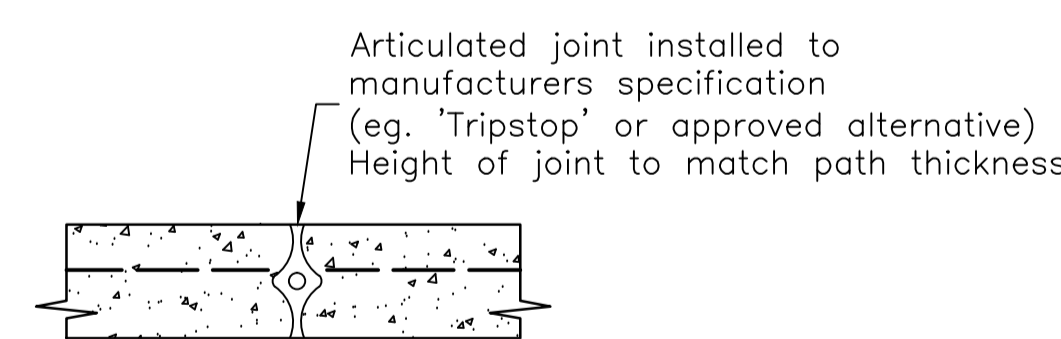

ARTICULATED JOINT - AJ
• Articulated joint system used at trees only and must comprise minimum 5 articulated joints
• Spacing is equal to path width eg. 1.5m spacing for 1.5m wide path

CONSTRUCTION JOINTS

No.	DATE	DESCRIPTION	AP'D
D	13/05/2015	CONCRETE GRADE AND THICKNESS AMENDED TO COMPLY WITH AS3600	
C	25/06/2014	DRAWING REVIEWED	
B	15/05/2012	CONCRETE STRENGTH, PATH ALIGNMENT AND JOINTS AMENDED	
A	12/02/10	ORIGINAL ISSUE	
REVISIONS			

NOTES : Supersedes COT Dwg 10066

Full Size A1
Not to scale

DRAWN: DESIGN OFFICE
CHECKED: GRP
Design Engineer Approved: Original signed by J EL-KHOURI
Date: 14/5/2015
Manager Approved: Original signed by M WILKINSON
Date: 14/5/2015

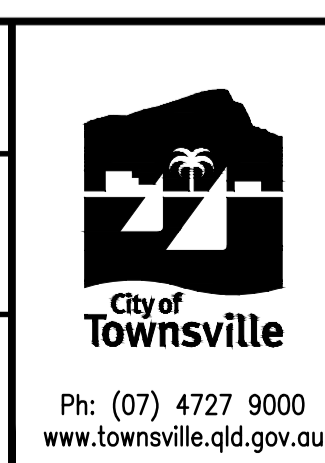

CONCRETE PATHWAY
REINFORCED CONCRETE (MESH) ALTERNATIVE

STANDARD DRAWING
ROADWORKS
SD-070 | D